

SERIES #41276 > 200 #316 Threaded Globe Valve



Figure # 41276 = 200#, 316, NPT, Globe Valve

Product Description

Investment Casting
Screwed-in cap
Rising Stem
Solid wedge disc
Hand wheel Operation
Thread ends conform to ASME B1.20.1 (NPT)
200 W.O.G.
Maximum working temperature: 350° F Test and Inspection to API 598

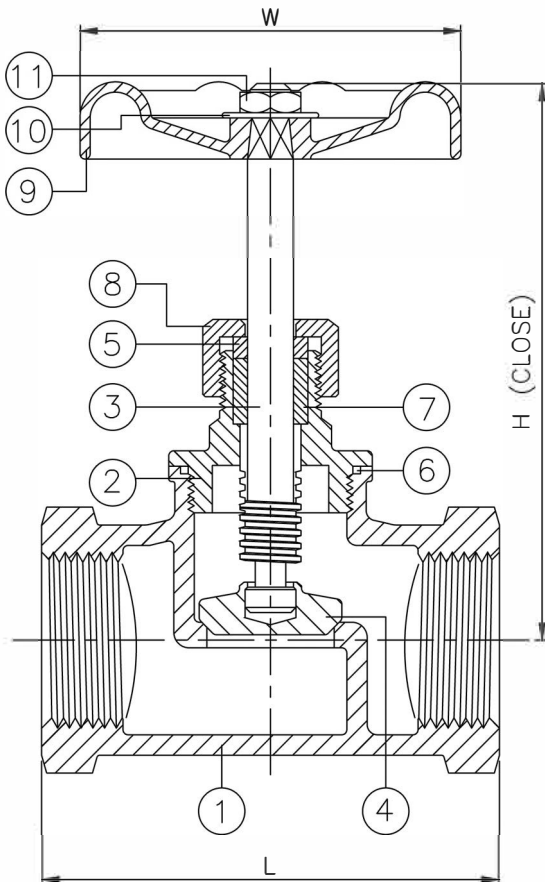

ITEM	PARTS	MATERIAL
1	BODY	ASTM A351-CF8M
2	BONNET	
3	STEM	AISI 316
4	DISC	ASTM A351-CF8M
5	GLAND RING	AISI 316
6	GASKET	PTFE
7	PACKING	
8	GLAND NUT	ASTM A351-CF8M
9	HANDLE WHEEL	FCD
10	SPIN WASHER	AISI 304
11	NUT	

NPS	L	H	W	Weight/LB
1/2"	1.97	4.17	2.44	0.88
3/4"	2.28	4.17	2.44	1.10
1"	2.76	4.57	2.95	1.43
1-1/4"	3.23	4.80	2.95	1.98
1-1/2"	3.46	5.67	3.74	2.98
2"	4.33	5.71	3.74	3.53

151 Memorial Drive, Suite A
 Shrewsbury MA 01545
 Toll Free: 1-866-59SIMCO (866-597-4626)
 Phone: 508-845-3300
 Fax: 508-845-3304
 info@simcovalve.com
 www.simcovalve.com

SIMCO
 Valve Company, Inc. **SVG**