

*Your Premiere Source For Quality Valve Products*

## Series #30 Ball Valve - 2 Piece Full Port



### Features & Benefits

- **Economical 2-Piece Design**
- **Full Port**  
Full port construction improves flow characteristics for greater process efficiencies.
- **Blow-out Proof Stem**  
Stem is bottom loaded to prevent removal when valve is in service.
- **Locking Handle**  
Enables plant personnel to secure valve in open or closed position when manually operated.
- **Corrosion Resistant**  
Made of 316 Stainless Steel (A351 GR.CF8M) For superior chemical resistance and longer service life.
- **Investment Cast**  
Improves dimensional control and reduces porosity.

### Operating/Test Conditions

- **Temperature Range (RTFE) -20°F to 450°F**
- **Maximum working pressure: 1000 W.O.G**
- **NPT ENDS conform to ASME B1.20.1**
- **Applicable standards: Test and Inspection API 598**

### Pressure & Temperature Chart

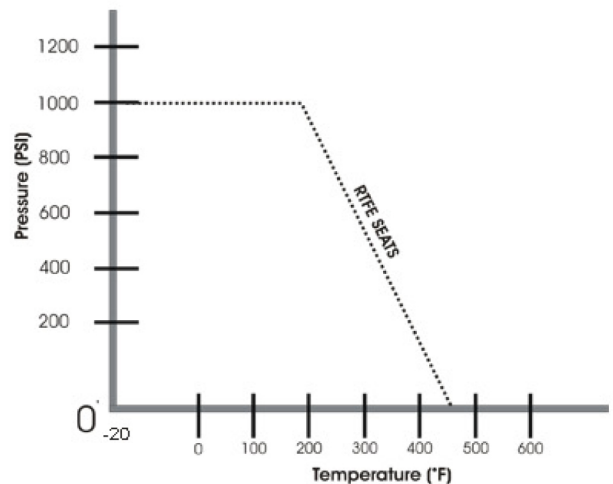

### Options

- **Oval Handles**

### Schematic Diagram

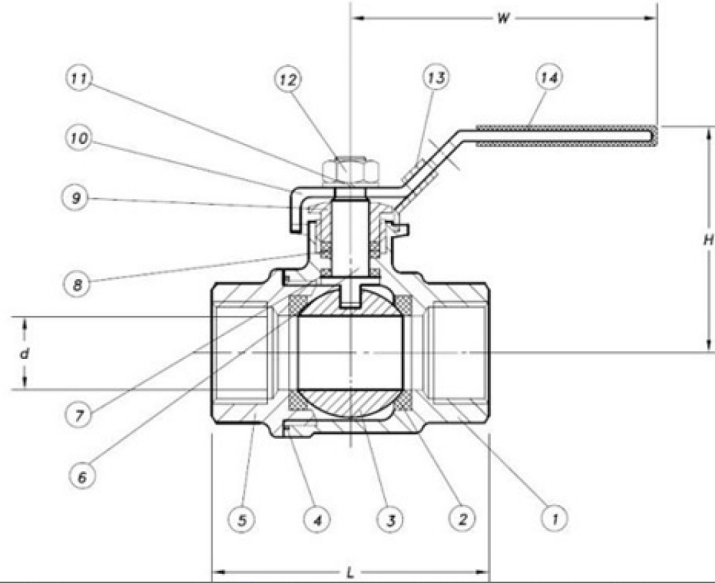

### Materials & Measurements

	d	L	H	W	Torque (in lbs.)	Weight (in lbs.)	†
1/4"	0.46	1.93	1.89	3.94	35	0.48	
3/8"	0.49	1.93	1.89	3.94	35	0.48	
1/2"	0.59	2.17	2.05	3.94	55	0.50	
3/4"	0.79	2.60	2.45	4.53	71	0.97	
1"	1.00	3.09	2.95	5.91	88	1.32	
1-1/4"	1.25	3.54	3.15	5.91	124	2.31	
1-1/2"	1.50	3.83	3.75	7.09	221	3.26	
2"	2.00	4.73	4.33	7.09	354	5.75	
2-1/2"	2.56	5.79	4.69	9.65	425	10.36	
3"	3.00	6.77	5.32	9.65	708	15.85	
4"	3.70	9.45	6.30	10.95	912	35.50	

ITEM	PARTS	MATERIAL
1	Body	ASTM A351 - 316 CF8M
2	Ball Seat	RPTFE (15%)
3	Ball	316 STAINLESS STEEL
4	Body Gasket	PTFE
5	Cap	ASTM A351- 316 CF8M
6	Stem	316 STAINLESS STEEL
7	Thrust Washer	PTFE
8	Packing	SS304
9	Gland Nut	
10	Handle	
11	Washer	
12	Nut	
13	Lock Device	PLASTIC
14	Plastic Cover	

**Investment Casting Ball Valve, Full Bore, Screw End, 1000 WOG**

- Investment Casting for Body and Cap
- Threaded Ends: ANSI B2, 1, BS 21, DIN 259/2999
- Internal Entry Blow-Out Proof Stem
- Pressure Rating: 1000psi (PN63)
- Material: See Table (Left)
- Pressure Test: API 598

### HOW TO ORDER

VALVE SIZE	VALVE SERIES	BODY	BALL & STEM	SEAT	ENDS	OPTIONS
1/4" -4"	30= 2PC Full Port	6=316ss	6=316ss	R=RTFE	TE=NPT	OH=Oval Handle